



**Instruction Manual**  
motoscope Chronoclassic 2

Multi-purpose instrument



V1.0

Thank you for purchasing a quality product from motogadget.  
The motoscope pro was developed in Germany and is elaborately handcrafted in Berlin.

Please read the following information and recommendations carefully and follow these instructions when installing and using the product. Motogadget accepts no liability for damage or defects resulting from negligence or failure to follow the installation and operating instructions.

motogadget GmbH  
Wollenberger Str. 4i/j  
13053 Berlin, Germany

Tel. +49 (0)30-6900410-0  
motogadget.com  
info@motogadget.de

Copyright © 2023 *motogadget* GmbH, Berlin.  
*motogadget* is a registered trademark of  
*motogadget* GmbH, Berlin, Germany.

## **1 Checking the delivery**

Every motogadget product is delivered in perfect working order. Please check that the goods you receive have not been damaged in transit. If there is any damage or the packaging has been opened, please contact us immediately. Our general terms and conditions apply. If a return is agreed with us, please ensure that we only accept goods in their original packaging and without signs of use within the statutory periods. We accept no liability for returns that are inadequately insured or packaged.

## **2 Disclaimer**

**MOTOGADGET ACCEPTS NO LIABILITY FOR DIRECT, INDIRECT OR CONSEQUENTIAL DAMAGE OF ANY KIND ARISING FROM THE USE, INSTALLATION OR CONNECTION OF THE INSTRUMENT, SENSORS OR ACCESSORIES SUPPLIED. THIS INCLUDES, BUT IS NOT LIMITED TO, ANY PERSONAL INJURY, PROPERTY DAMAGE OR FINANCIAL LOSS. IN PARTICULAR, USE ON PUBLIC ROADS IS AT YOUR OWN RISK.**

**THE DISPLAY IS MADE UP OF 512 INDIVIDUAL LEDS. FOR A DEFECT TO BE COVERED BY THE WARRANTY, AT LEAST 2 LEDS MUST BE DEFECTIVE. DO NOT OPEN THE HOUSING. DOING SO WILL INVALIDATE ALL WARRANTY CLAIMS. USE OF THE SUPPLIED INSTRUMENTS, SENSORS AND ACCESSORIES IN RACING OR COMPETITION CONDITIONS, OR ANY OTHER USE NOT IN ACCORDANCE WITH THE INTENDED USE, WILL INVALIDATE ALL WARRANTY CLAIMS.**

## 2.1 Duty of registration / ABE

The motoscope Chronoclassic 2 has a general operating permit (ABE) and therefore does not need to be entered in the vehicle documents. The ABE is marked „KBA 91262“ on the back of the device. You can find the document here:

<https://manuals.motogadget.com/motoscope-chronoclassic-2/en/>

**THE ABE IS ONLY VALID IF MOUNTED ON TWO- OR THREE-WHEELED VEHICLE AND THE WHEEL CIRCUMFERENCE HAS BEEN ENTERED IN THE SETUP ACCORDING TO THE INTENDED TIRE ROLLING CIRCUMFERENCE (TABLE IN APPENDIX). YOU ARE RESPONSIBLE FOR THE CORRECT SETTING OF THE WHEEL CIRCUMFERENCE AND THE NUMBER OF WHEEL PULSES AS WELL AS FOR THE CORRECT INSTALLATION OF THE SPEEDOMETER SENSOR.**

## 3 Technical Data

• Mounting diameter x depth	80 mm x 34 mm
• Weight incl. connection cable	220 g
• Mounting threads	3 x M3, 4 mm deep
• Power consumption	max. 200 mA
• Standby current	400 $\mu$ A
• Operating voltage	9 – 15V
• Operating Temperature	-20°... + 80°
• Display	motogadget - DOT Matrix made from 512 individual LED

## 4 Safety Advice

- BEFORE CARRYING OUT ANY WORK ON THE VEHICLE'S ELECTRICAL SYSTEM, DISCONNECT THE BATTERY. TO DO THIS, FIRST DISCONNECT THE NEGATIVE TERMINAL THEN DISCONNECT THE POSITIVE TERMINAL. WHEN RECONNECTING PROCEED IN REVERSE ORDER.
- ENSURE THAT THE VEHICLE IS STABLE BEFORE STARTING THE INSTALLATION WORK.
- USE ON VEHICLES WITH BATTERY POSITIVE TERMINAL CONNECTED TO VEHICLE GROUND IS NOT POSSIBLE.
- USE ON VEHICLES WITH A 6V VEHICLE ELECTRICAL SYSTEM IS NOT POSSIBLE.
- USE ON VEHICLES WITHOUT A BATTERY IS NOT POSSIBLE.
- INSTALLATION AND CONNECTION MAY ONLY BE CARRIED OUT BY QUALIFIED SPECIALIST PERSONNEL.
- ALL CABLE CROSS-SECTIONS MUST BE DIMENSIONED ACCORDING TO THE CURRENT FLOW.
- THE VEHICLE MUST HAVE A EMI (Electromagnetic Interferences) SUPPRESSED IGNITION SYSTEM  
ALL ELECTRICAL CONNECTIONS IN THE WIRING HARNESS AND AT THE TERMINALS MUST BE MADE PROPERLY AND CORRECTLY.

## **5 Plug & Ride**

The Plug&Ride versions of the Chronoclassic are equipped with a suitable vehicle plug and mounting plate. No adjustments need to be made to the instrument. Only the approved vehicle models and model years are compatible.

### **BMW R9T 2017 - 2023**

Loosen the two fastening screws on the holder of the original instrument, disconnect the plug from the instrument, remove the instrument with holder. Attach the Chronoclassic retaining plate to the fork bridge using the two screws and plug the connector into the vehicle wiring harness. Route the plug connection under the tank. Riding modes, heated grips and the motoscope pro are operated using the original buttons on the handlebars. Certain functions such as switching off the alarm system or cruise control cannot be operated via the Chronoclassic.

### **Harley Davidson BigTwins ab 2011, Sportster ab 2014 (HDLAN)**

Replace the original handlebar clamping plate with the Chronoclassic bracket. Route the cable under the tank to the OBD (onboard diagnostics) connector and plug it in. Certain functions such as the fuel gauge and deactivating the alarm system cannot be displayed or operated via the Chronoclassic.

## **6 Attachment**

The instrument is mounted on a flat surface without distortion using three M3 screws. The minimum screw-in depth is 2mm. The tightening torque is 1Nm. The use of liquid, medium-strength threadlocker is recommended.

## **7 Connection**

### **7.1 How to route wires**

Before starting, look for a suitable cable route. It should be as far away as possible from hot engine parts. Look for a suitable place to join cables and if necessary connection plugs as well. There are usually similar connection points in the wiring harness in the headlight, under the tank or in the cockpit.

Before shortening the cables, make sure they are long enough. Also consider the steering angle and suspension travel of your vehicle. All connection cables should be laid without kinks, strain-relieved and well insulated. It is best to use the crimp connectors supplied. Pay particular attention to additional insulation protection at points subject to greater mechanical stress. We recommend using plastic cable ties to lay and secure the cables.

### 7.1.1 Assignment and cable colors

<b>Cable color</b>	<b>Function</b>	<b>Assignment</b>
<b>red</b>	power supply	Battery plus pole (fused with 1A)
<b>black</b>	power supply	vehicle ground
<b>brown</b>	ignition lock	switched battery plus (clamp 15)
<b>white</b>	Speedsensor	to signal of OEM speedsensor or to motogadget speedsensor
<b>green</b>	Menu button	to menu push-button, switching to ground
<b>orange</b>	LIN BUS	to Breakout Box
<b>yellow</b>	Tachometer	to ignition coil clamp 1 (switched ground from ignitionbox)
		<b>DO NOT CONNECT TO HIGH VOLTAGE PARTS</b>
		If use with CDI-Ignition, a motogadget ignition pickup is required (SKU 9000001, sold separately)
<b>purple</b>	CAN BUS	do not connect
<b>blue</b>	CAN BUS	do not connect



## **7.2 Battery and power supply**

The ChronoClassic works with voltages from 9V to 15V DC. Operation on vehicles without a 12V battery in the vehicle electrical system is not possible. It cannot be used on vehicles with a positive battery terminal on the vehicle frame. Please ensure that the polarity of the supply voltage is correct during installation.

THE MINIMUM CROSS-SECTION TO BE USED FOR ALL CONNECTION CABLES IS 0.5 MM<sup>2</sup>. THE RED CABLE MUST BE PROTECTED WITH A 1A FUSE. IF IN DOUBT, HAVE THE CONNECTION CARRIED OUT BY A SPECIALIST WORKSHOP.

## **8 Menu button, Tachometer, Speedometer**

### **8.1 Menu button**

The instrument is operated via a push-button. One pole of the button is connected to the green cable, the other pole of the button is connected to vehicle ground. The polarity of the button does not matter.

### **8.2 Tachometer**

All ignition systems that work with ignition coils are compatible. Connect the yellow connection cable to terminal 1 (switched ground from the ignition box) of any ignition coil. Connection to CDI ignitions (scooters, quads, enduros) is possible with the separately available motogadget ignition signal pickup (item 9000001).

The ignition system must be fault-free for the speed display to function correctly. Settings must also be made in the instrument setup. Please follow the instructions in the corresponding chapter.

THE YELLOW CABLE IS CONNECTED TO THE PRIMARY CIRCUIT OF THE IGNITION COIL. IT MUST NEVER COME INTO CONTACT WITH THE HIGH-VOLTAGE CIRCUIT.

## **8.3 Installing and connecting the speedometer sensor**

### **8.3.1 Use of the original speedometer sensor**

If the vehicle has an electronic speedometer sensor with three connection cables that outputs a ground signal, this can be used. Hall sensors (two connections) are not compatible with the Chrono-classic. The signal cable of the sensor is connected to the white connection cable of the instrument. If no speedometer signal can be detected, the motogadget speedometer sensor included in the scope of delivery is used.

### **8.3.2 Using the motogadget speedometer sensor**

The speedometer sensor supplied is a reed switch. The magnet supplied is attached to a wheel using 2-component epoxy adhesive, whereby the distance between the magnet and the wheel axle can be as desired. The speedometer sensor is attached to the vehicle with a retaining plate so that the magnet and sensor are parallel to each other. The distance between magnet and sensor must not exceed 4 mm and the sensor must not touch the magnet. The retaining plate must be stable enough to ensure that the distance does not change even when the vehicle is in motion. The tightening torque of the sensor nuts is 1.6 Nm, use screw adhesive (medium strength). One cable of the sensor is connected to ground, the other to the white cable of the instrument. Please note: the magnet demagnetizes at temperatures above 100°C (hot brake system).

## 9 Start-up

Once all parts are securely fitted and correctly connected, the battery can be reconnected. Switch on the vehicle's electrical system, the display should light up and the word "motogadget" should appear. If not, switch off the ignition and systematically check all instrument connections.

## 10 Operation

The menu is navigated using the button or the touch function by touching the lower centre of the screen (above the motogadget logo). The touch sensitivity is designed for use with gloves. Drops of water may trigger the touch function, in which case the touch function is disabled until the motoscope pro is restarted. The menu levels are selected and the setup menu is called up by varying the activation time of the button/touch function. There are 4 different activation times:

- |                          |  |
|--------------------------|--|
| <b>stage 1</b> - brief   | Select the next / other option or increment a digit.     |
| <b>stage 2</b> - 1s - 2s | Toggle between displays.                                 |
| <b>stage 3</b> - 2s - 4s | Deleting memory values (e.g. maximum values, trip, etc.) |
| <b>stage 4</b> - hold    | Entering setup menu, exiting setup menu                  |

The Chronoclassic is available with a speedometer or tachometer scale.

The speed indicated by the dial is limited to 200 km/h or mph. If the speed exceeds 200 km/h or mph, the speed is displayed as a numerical value on the top line of the display. The two-line dot-matrix display, consisting of 512 individual LEDs, shows the gear position on the left-hand side of the top line and the speed (tachometer scale) or revs (speedometer scale) next to it. The menu button can be used to display different values on the bottom line of the display. Warning messages (e.g. oil pressure, reserve) are indicated by the corresponding warning light in combination with a message on the second line of the display.

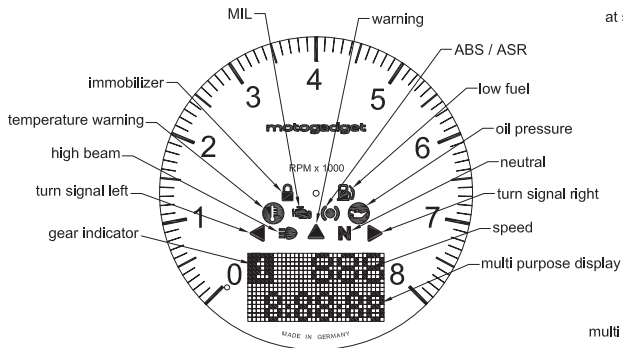

tachometer scale

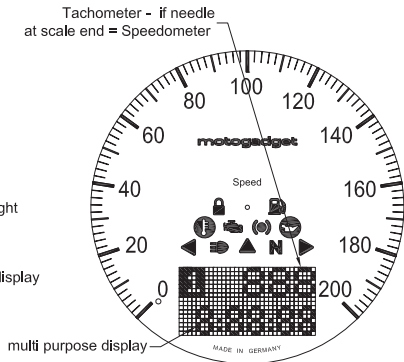

speedometer scale

# Menu diagramm

stage 1: menu button < 1s ▶  
stage 2: menu button 1 - 2s ▶▶  
stage 3: menu button 2 - 4s ▶▶▶  
stage 4: menu button > 4s ▶▶▶▶

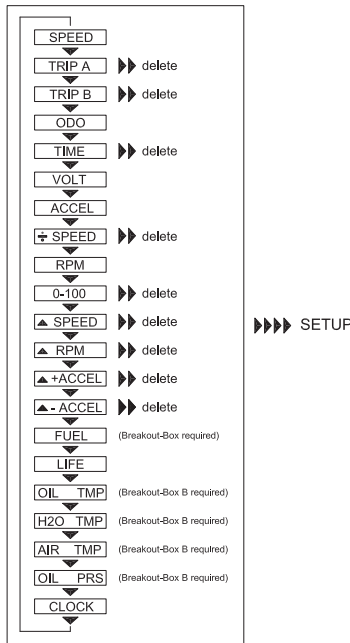

## 10.1 Display values

### **SPEED**

Speed display from 0 to 999 km/h or mph. If you switch to another display on the second line and the vehicle is moving, the system will automatically return to the SPEED display after a certain time. For this to happen, the ABACK (Autoback) function must be activated in the Setup menu. When ABACK is active, SPEED is always shown on the large display when the instrument is switched on.

### **TRIP A**

Display of the trip odometer up to 999.9 km or ml. This value is reset with button level 3

### **TRIP B**

Display of the trip odometer up to 999.9 km or ml. This value is reset with button level 3

### **ODO** (odometer)

Display of the total odometer reading up to 999999 km or ml. This value can be changed in the setup.

### **TIME**

Display of the journey time in the format 59min:59s:99, if the measured journey time exceeds one hour, the display is in the format 99h.59min:59s. The time measurement starts when a speed signal is present and stops when the vehicle is stationary.

## **VOLT**

Display of the on-board voltage from 9-16V.

If the voltage falls below a defined value, the warning message LOW VOLTAGE can be generated.

## **ACCEL** (acceleration)

Display of the current acceleration in G. The value of  $9.81 \text{ m/s}^2$  corresponds to one G.

If the acceleration is negative (braking), a minus sign appears in front of the display value.

## **% SPEED**

Display of the average speed. This value is reset with button level 3.

## **RPM** (revolutions per minute)

Numerical display of the engine revolutions up to 19999 RPM.

## **0-100**

Time measurement of acceleration from 0-100 km/h (or 0-60 mph).

To activate the time measurement, the currently displayed value must be deleted with button level 3.

The measurement is ready when the vehicle is stationary and starts automatically at the first speed pulse. The measurement stops when 100 km/h is reached..

## **max. SPEED**

Display of the maximum speed reached. This value is reset with push-button stage 3

## **max. RPM**

Display of the maximum speed reached. This value is reset with push-button stage 3.

**max. +ACCEL**

Display of the maximum positive acceleration achieved. This value is reset with button stage 3.

**max. -ACCEL**

Display of the maximum negative acceleration achieved. This value is reset with button stage 3.

**FUEL**

Breakout box A or B (article 1005040 or 1005041) and the use of a resistor float switch on the vehicle are required. Display of the tank content from 0 - 100%. Deactivate display for both displays if no tank sensor or a reserve float switch or a thermistor tank sensor is used on the vehicle. The warning message LOW FUEL can be generated if the fuel level falls below a defined value.

**LIFE**

Operating hours counter up to 9999 h. The operating hours counter is active when the instrument is switched on. This function can be reset in the setup. If a defined value is exceeded, the SERVICE warning message can be generated.

**OIL TMP**

Breakout box B (SKU 1005041) and temperature sensor (article 9001002) required.

Displays the oil temperature in the range from +40 to +150°C. Below +40°C „cold“ is displayed, above 150°C „hot“ is displayed. If no sensor is connected, „-“ is displayed. The temperature can also be displayed in °F. If a defined value is exceeded, the warning message OIL HOT can be generated.



## **H2O TMP**

Breakout box B (SKU 1005041) and temperature sensor (article 9001002) required.

Displays the water temperature in the range from +40 to +120 °C. Below +40°C „cold“ is displayed, above 120°C „hot“ is displayed. If no sensor is connected, „-“ is displayed. The temperature can also be displayed in °F. If a defined value is exceeded, the warning message H2O HOT can be generated.

## **AIR TMP**

Breakout box B (SKU 1005041) and temperature sensor (article 1005090) required.

Displays the air temperature in the range from -20 to +80 °C. Below -20°C „cold“ is displayed, above 80°C „hot“ is displayed. If no sensor is connected, „-“ is displayed. The temperature can also be displayed in °F. If the temperature falls below a defined value, the AIR COLD warning message can be generated.

## **OIL PRS**

Breakout box B (SKU 1005041) and the oil pressure sensor (item 9001020) are required.

Displays the oil pressure in the range from 0.5 to 8.0 bar. The pressure can also be displayed in PSI. If the pressure falls below a defined value, the warning message OIL PRS can be generated.

## **CLOCK**

Displays the time in 24h format.

## **11 Setup**

All the settings of the instrument are made in the Setup menu. To access it, press the key until the setup menu starts. The setup menu is divided into 5 main menus: SCREEN, PARAM, CONFIG, MESSAGE and SYSTEM. Navigation is by means of key levels 1 to 3, where level 1 is used to change a value, level 2 is used to activate the selected menu or to change a position and level 3 is used to exit a menu.

### **11.1 SCREEN**

The second line of the display is configured in this main menu. All display values can be activated or deactivated with keypad level 2, with keypad level 1 switching to the next display value. This main menu is exited with key level 3.

### **11.2 PARAM**

All vehicle-specific parameters are set in this main menu. Button level 1 is used to switch between parameters. Step 2 calls up the parameter to be configured and step 3 switches back to the main menu.

The following parameters can be changed:

## **CLOCK**

Set the time. Button level 1 increments the active digit, level 2 toggles between the digits, level 3 exits the menu and returns to the main menu PARAM

## **CIRC** (circumference)

This function is used to enter the wheel circumference in millimetres. Key level 1 increases the active digit, button level 2 switches to the next digit and button level 3 exits the menu and returns to the main PARAM menu. The appropriate rolling circumference for the tyre is taken from the table in the appendix; the ABE is only valid with the appropriate value from this table. If your tyre is not listed in the table, measure the circumference of the wheel on which the speedometer sensor is mounted using a piece of string. Add a speedometer lead of 5% by multiplying the measured value by 1.05. If the SPEED TEACH function is used, nothing needs to be set in this menu.

## **ImpW** (input wheel)

Setting the tachometer sensor pulses per wheel revolution from 1 - 99. Button level 1 increments the active digit, level 2 switches to the next digit, level 3 exits the menu and switches back to the main PARAM menu. If exactly 1 magnet is used, nothing needs to be changed (factory setting). If you use more than 1 magnet, set the number of magnets used. If the original speedometer sensor is used, set the number of speedometer sensor pulses per wheel revolution. If the speedometer sensor is taught using the SPEED TEACH function, the parameter ImpW is not changed.

### **ImpE** (input engine)

This function is used to set the number of ignition pulses per crankshaft revolution. Button level 1 switches to the next value, level 3 exits the menu and switches back to the main PARAM menu. If the vehicle has several ignition coils, only the pulses of the ignition coil to which the signal cable is connected are relevant.

### **Examples:**

Single cylinder, 4-stroke, one ignition coil ImpE= 0.5 (SR 500, XT 500)

Four-cylinder, 4-stroke, two ignition coils ImpE= 1 (GSXR 1000)

Two-cylinder, 4-stroke, one ignition coil ImpE= 1 (Harley Davidson, dual fire)

Two-cylinder, 4-stroke, two ignition coils ImpE=0.5 (Harley Davidson, single fire)

### **How do I know my setting option?**

For most vehicles, the setting value is 0.5 or 1. Please select option 1, exit setup and start the engine. If half the idling speed is displayed, set the value to 0.5.

### **ImpF** (input filter)

This function is used to set the input filter for the speed measurement. Button stage 1 switches between the values A, B, C and D. Button level 3 closes the menu and returns to the main menu PARAM. If the speed display does not work satisfactorily with filter B, please try one of the other filters.

### **SCAL**

Setting the scaling of the speed band in the ranges 0 - 2000, 4000, 6000, 8000, 10,000, 14,000 and 16,000 rpm. Button stage 1 changes to the next scale, button stage 3 exit the menu back to the main PARAM menu.

## **UNIT**

Selection of the display unit for distance (kilometers or miles), temperature (°Celsius or °Fahrenheit) and pressure (bar or PSI). Button stage 1 switches between distance, temperature and pressure, button stage 2 selects the selected unit, which can then be changed with button stage 1. Button stage 3 switches back to the selection option. Pressing button stage 3 again closes the menu and returns to the main PARAM menu.

## **FLASH**

Setting the speed limit for the switching flash (red area). If the set value is exceeded, the entire display flashes red. The speed limit can be set in steps of one hundred from 100 - 19,900 rpm. This function is deactivated when all digits have been set to zero. Button stage 1 increments the active digit, button stage 2 moves to the next digit, button stage 3 exits the menu and returns to the main PARAM menu.

## **11.4 CONFIG**

All device-specific parameters are set in this main menu. Button stage 1 is used to switch between parameters. Button stage 2 calls up the parameter to be configured and stage 3 switches back to the main menu. The following parameters can be changed:

### **BRIGHT**

This function can be used to choose between automatic brightness control or a fixed value of 1-15. We recommend retaining the automatic brightness control (factory setting). Button stage 1 switches to the next brightness level, button stage 3 exits the menu and switches back to the CONFIG main menu.

## **FUEL**

Programming the tank sensor on the vehicle. Activate the FUEL SET function with button level 2. Use button level 1 to switch between programming the full tank (triangle pointing upwards) and the empty tank (triangle pointing downwards). Teach-in with an empty tank at a petrol station. To do this, with an empty tank, first select the option of programming the empty tank (triangle with tip pointing downwards) using button level 2. If the petrol level is successfully programmed, a number with the measured resistance value of the tank sensor appears behind the triangle. The vehicle is now filled up with petrol and, after waiting 10 minutes, the option to learn the full tank (triangle with tip pointing upwards) is selected with button level 2. If the petrol level is successfully programmed, a number with the measured resistance value of the fuel level sensor appears behind the triangle. The measurement of the full or empty petrol tank can be carried out independently at any time. Button level 3 exits the menu and returns to the main menu CONFIG.

## **SENSOR**

Configuration of the speedometer sensor used between output signal +12V or ground (PNP or NPN). If the vehicle's original speedometer sensor is used and no speed is displayed after the sensor has been taught (see below), change this value.

## **SPEED**

This function enables automatic calibration of the driving speed if, for example, the wheel circumference or pulses per wheel revolution are not known. To do this, drive at a constant speed of 50 km/h (controlled by an escort vehicle or the original instrument if necessary).

Start SPEED TEACH by pressing button level 2. Calibration takes place over a period of 5 seconds. This time is indicated by a slowly increasing LED bar. At the end of the measurement, the instrument returns to the standard display.

## **GEAR**

This menu is used to learn the gear display. Press button level 2 to enter the menu, Gear1 is displayed. With button level 1 you can select between 1st and 6th gear. Button level 2 starts the measurement process for the gear displayed - IMPORTANT: you must already be driving in this gear. Do not change gear or disengage the clutch during the measurement. You can accelerate and brake slightly during the test drive, but the tyres must not spin or stop. Check that the gear indicator is correct. An incorrect gear may be displayed briefly at the limits. If the overall result is incorrect, the learning process must be repeated. If the gear indicator does not work correctly for a gear, the gear can be relearned. If the gear ratio, tyre size or speedometer sensor pulse count is changed, all gears must be relearned. Teach the gears away from public traffic on a closed, suitable route. The measurement is carried out at your own risk.

## **ABACK** (auto back)

Setting after which time the system automatically jumps back from the current display to the speed display. In the factory setting, ABACK is deactivated (00s). Only in this case will the current screen be displayed again after switching off and on. Button level 1 is used to select between 00, 10, 20, 30s, button level 3 exits the menu and returns to the main menu CONFIG.

## **11.5 MESSAGE**

Configuration of error messages.

A error message is shown in the small display with a flashing warning light. Confirm with button stage 2, shows ACKN (acknowledge) briefly. The error message disappears and the warning light stay lit. The error message is displayed again after a instrument restart. The warning light goes out and the message disappears when the error has been resolved.

### **OIL SW**

If the oil pressure switch remains active at a engine speed above 1000 rpm, the message OIL PRS is displayed. In this menu, the message is activated or deactivated with button stage 2 and the menu is exited with button stage 3.

### **OIL SNR**

If an oil pressure sensor is used with breakout box B, this menu can be used to define an oil pressure below which the message OIL PRS is displayed at a speed of more than 1000 rpm. In this menu, the selected digit is increased by one with button stage 1, the digit is changed with button stage 2 and the menu is exited with button stage 3. The value 0.0 bar deactivates the message.

### **OIL TMP**

If an oil temperature sensor is used with breakout box B, this menu can be used to define a temperature above which the message OIL HOT is displayed. In this menu, button stage 1 increases the selected digit by one, button stage 2 changes the digit and button stage 3 exits the menu. The value 000°C deactivates the message.



## **H2O TMP**

If a water temperature sensor is used with breakout box B, a temperature can be defined in this menu, above which the message H2O HOT is displayed. In this menu, button stage 1 increases the selected digit by one, button stage 2 changes the digit and button stage 3 exits the menu. The value 000°C deactivates the message.

## **VOLTAGE**

A voltage can be defined in this menu, below which the message LOW VOLTAGE is displayed at a engine speed above 1000 rpm. In this menu, the selected digit is increased by one with button stage 1, the digit is changed with button stage 2 and the menu is exited with button stage 3. The value 00.0 V deactivates the message.

## **ENGINE**

If the breakout box input ERROR is connected to 12V at a engine speed above 1000 rpm, the CHECK ENGINE message appears. In this menu, the message is activated or deactivated with button stage 2.

## **FUEL**

A fuel level can be defined in this menu, below which the message LOW FUEL is displayed. In this menu, button stage 1 is used to increase the selected digit by one, button stage 2 is used to change the digit and button stage 3 is used to exit the menu. The value 00 % deactivates the message. If a float switch on the vehicle or a thermistor is used to display the tank reserve, the value 50% is set. In this case, the FUEL option is also set to OFF in the SCREEN1 and SCREEN2 setup menus.

## **AIR TMP**

If an air temperature sensor is used with breakout box B, a temperature can be defined in this menu below which the message AIR COLD is displayed. In this menu, button stage 1 increases the selected digit by one, button stage 2 changes the digit and button stage 3 exits the menu. The value 00.0°C deactivates the message.

## **SERVICE**

In this menu, an operating hours value can be defined, above which the CHECK SERVICE message is displayed. In this menu, button stage 1 increases the selected digit by one, button stage 2 changes the digit and button stage 3 exits the menu. The value 00000 h deactivates the message.

## **11.6 SYSTEM**

All system-specific parameters are set in this main menu. Button stage 1 is used to switch between parameters. Button stage 2 calls up the parameter to be configured and button stage 3 switches back to the main menu. The following parameters can be changed:

### **ODO**

Setting the total odometer reading. Button stage 1 increments the active digit, button stage 2 switches to the next digit, button stage 3 exits the menu and switches back to the main SYSTEM menu.

## **RESET**

All parameter settings can be reset to the factory settings here. The operating hours counter and the total odometer reading are set to zero. Button stage 2 activates this menu, pressing button stage 2 again deletes all settings. This menu can be exited without deleting the settings by pressing button stage 1 or 3.

## **VERSION**

Displays the firmware version of the motoscope pro and the connected breakout box.

## **12 Safety advices for use of the motoscope pro in public traffic**

Do not allow the instrument to distract you from the road. As the user, you are responsible for the correct setting of all instrument parameters and the correct installation of all attachments. The installation of all sensors and the input of parameters must be carried out with the utmost care, as the accuracy of the display depends on it.

PLEASE DO NOT OPERATE THE INSTRUMENT WHILE DRIVING, AS THIS MAY LEAD TO LOSS OF CONTROL OF THE VEHICLE AND AN ACCIDENT.

## **13 Troubleshooting**

### **13.1 After installation and first start up**

- Ensure that the device has a sufficient supply voltage of 12V. Ensure that the vehicle battery is functioning properly.
- Do not use a battery charger to test the function of the device.
- Check all cables for correct connection and contact.
- Check all cables for polarity reversal, short circuit or short to ground.
- If a stable gear display is not achieved, check whether the speedometer sensor bracket is stable enough and the distance between the speedometer sensor and the magnet is less than 4 mm. Try out all speed filters.

## Checking the instruments functions

- Disconnect all connections to the unit.
- Connect the positive battery terminal to the brown and red wires. Connect the black cable to the negative terminal of the battery. The Chronoclassic 2 display should light up and „moto-gadget“ should appear; if it does not, check the power source and polarity.
- Tap the green wire to vehicle ground - if the displayed menus change, this input is working correctly.
- Tap the white wire to vehicle ground several times quickly - if the SPEED menu shows random numbers, this input is working correctly.
- Tap the yellow wire to vehicle ground several times quickly - if the RPM bar graph lights up, this input is working correctly.
- If this test is successful, the unit is working correctly.

## 13.2 Returns and complaints

- Check that there is no connection error. Use a different power source.
- Do not use a battery charger to check function.
- Shipping is at your own risk, you are responsible for adequate insurance and packaging of the shipment, freight collect shipments will not be accepted.
- Invoice and repair form must be enclosed.
- Shipments from outside the EU must be marked „Repair Device“ and a value of 1 Euro on the customs declaration.
- For service calls that are not due to a defect in the unit or its accessories, but are due to incorrect operation, adjustment, faulty connections or other vehicle-related faults, we charge a service fee of EUR 80.

## 14 Appendix

### 14.1 Wiring diagram

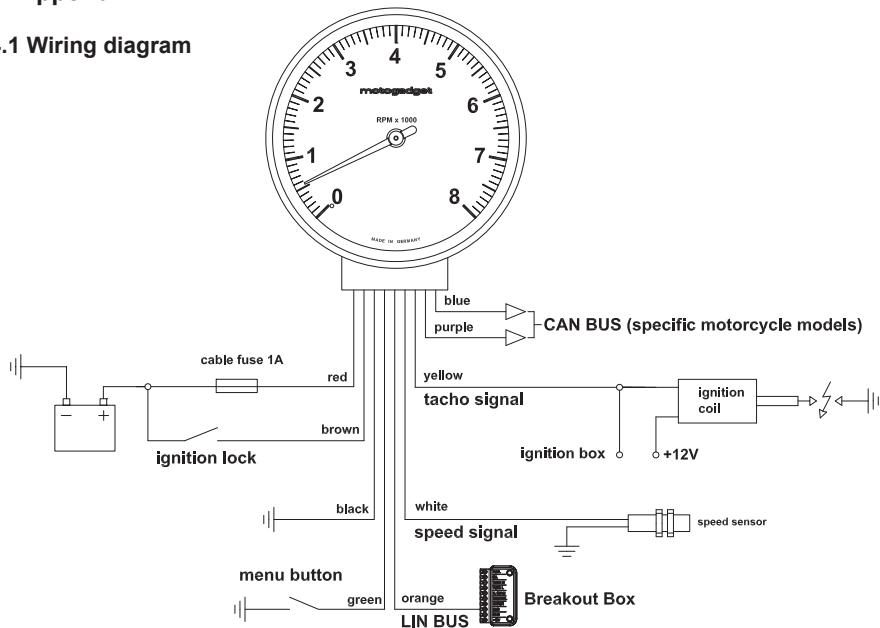

## 14.2 Dimensions

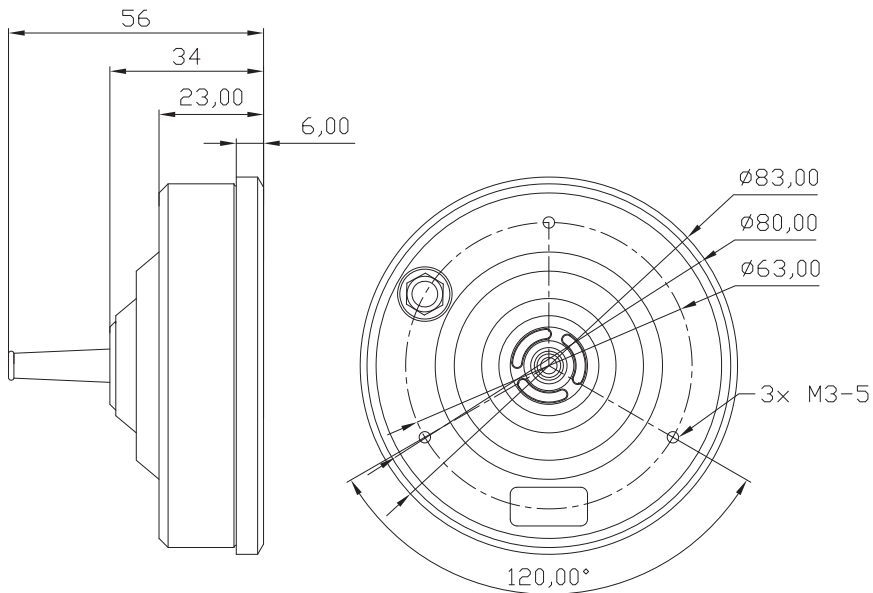

### 14.3 Connection diagram of the breakout box for indicator lamps and tank sensor

The breakout box is attached to a location protected from splash water using two cable ties, e.g. on the wiring harness. The screws and cable openings of the screw terminals must be protected from corrosion with contact grease. Strip 3 mm of insulation from the cable to be connected. The stripped cable end is bent and inserted into the wire end ferrule. The prepared cable is then screwed to the respective screw terminal. Only the motogadget temperature and pressure sensors can be used.

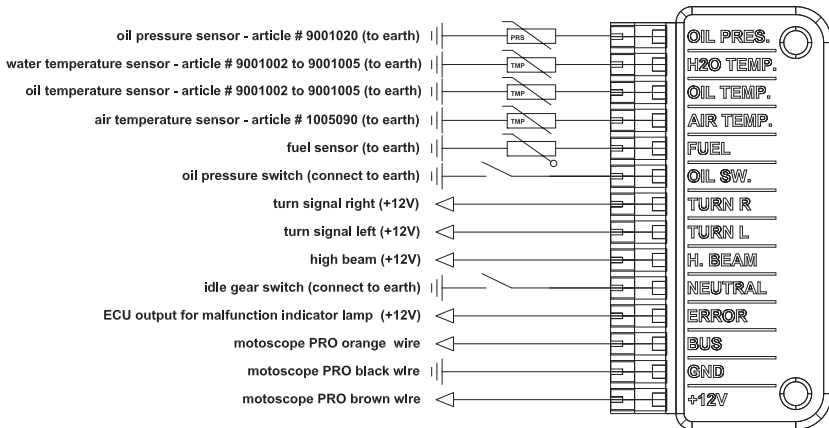



## Notes on fuel tank sensors:

In general, 3 different tank sensors are commonly used:

- 1) PTC resistors (e.g. Cagiva, Japan. models) - reserve lamp on/off
- 2) Float switch (e.g. HD Sportster) - reserve lamp on/off
- 3) Float resistors (e.g. HD Softail) - continuous measurement of tank level

Sensor types 2 and 3 can be connected directly to the FUEL input.

## Connection of a thermistor sensor:

A relay with a coil value of 70 to 150 Ohm must be connected as shown in the following illustration. Alternatively, the motogadget mo.relay can be used together with the motogadget load resistor. Hot wire tank sensors are very sluggish, so wait at least 10 minutes between connecting the empty tank and the full tank. If the connection is successful, the warning lamp lights up when the reserve level is reached and the message „LOW FUEL“ appears. It is not possible to display the tank level as a percentage.

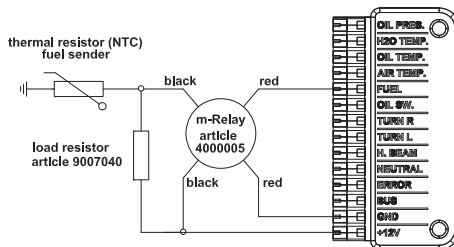
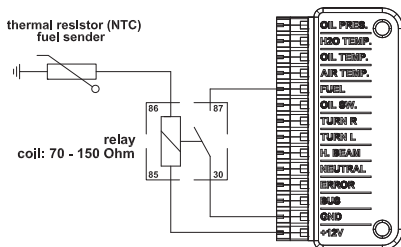

# 14.4 Setup Menu Diagramm

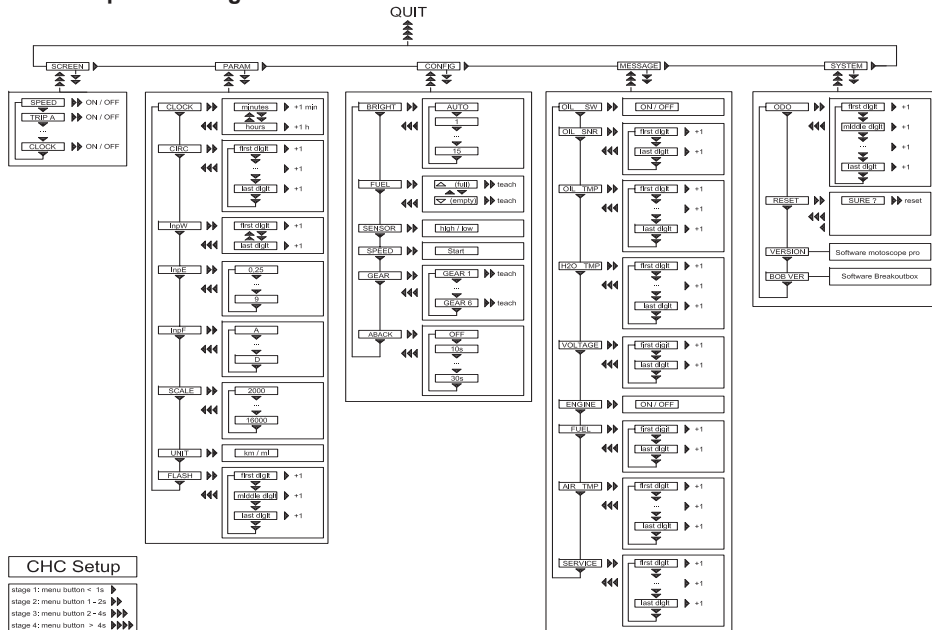

## CHC Setup

- stage 1: menu button < 1s ▶
- stage 2: menu button 1 - 2s ▶▶
- stage 3: menu button 2 - 4s ▶▶▶
- stage 4: menu button > 4s ▶▶▶▶

## 14.5 List of tire rolling circumferences

front wheel tire sizes and circumference settings			
16" tire inner diameter			
tire size	circumference (mm)	tire size	circumference (mm)
100/90-16	1770	130/70-16	1776
110/90-16	1824	130/90-16	1933
120/80-16	1806	150/80-16	1951
120/90-16	1878		
17" tire inner diameter			
tire size	circumference (mm)	tire size	circumference (mm)
100/80-17	1788	120/70-17	1812
110/70-17	1770	120/80-17	1884
110/80-17	1836	130/60-17	1776
120/60-17	1740	130/70-17	1854
18" tire inner diameter			
tire size	Abrollumfang (mm)	tire size	circumference (mm)
3.00-18	1894	110/80-18	1912
3.25-18	1930	110/90-18	1978
3.50-18	1960	120/70-18	1888
90/90-18	1869	120/80-18	1960
100/80-18	1863	120/90-18	2032
100/90-18	1924	130/70-18	1930
19" tire inner diameter			
tire size	circumference (mm)	tire size	circumference (mm)
3.00-19	1972	100/90-19	2002
3.25-19	2008	110/90-19	2057
3.50-19	2038		
21" tire inner diameter			
tire size	Abrollumfang (mm)	tire size	circumference (mm)
80/90-21	2045	90/90-21	2099

**rear wheel** tire sizes and circumference settings**15" tire inner diameter**

tire size	circumference (mm)	Reifengröße	circumference (mm)
100/90-15	1770	140/80-15	1827
110/90-15	1824	140/90-15	1912
120/80-15	1806	170/80-15	1972
120/90-15	1878	180/70-15	1912
130/70-15	1776	200/70-15	1996
130/90-15	1933		

**16" tire inner diameter**

tire size	circumference (mm)	tire size	circumference (mm)
100/90-16	1770	150/80-16	1951
110/90-16	1824	160/80-16	1999
120/80-16	1806	180/60-16	1878
120/90-16	1957	180/70-16	1987
130/70-16	1776	200/60-16	1924
130/90-16	1933	240/50-16	1951
140/90-16	1987		

**17" tire inner diameter**

tire size	circumference (mm)	tire size	circumference (mm)
120/90-17	1957	160/60-17	1884
130/70-17	1854	160/70-17	1981
130/80-17	1933	170/60-17	1921
130/90-17	2011	180/55-17	1903
140/80-17	1981	190/50-17	1878
150/60-17	1848	200/50-17	1919
150/70-17	1939	210/50-17	1919
150/80-17	2029		

**18" tire inner diameter**

tire size	circumference (mm)	tire size	circumference (mm)
110/80-18	1912	150/70-18	2014
110/90-18	1978	160/60-18	1960
110/100-18	2099	170/60-18	1996
120/90-18	2032	180/55-18	1981
130/80-18	2008	200/50-18	1951
140/80-18	2057	240/40-18	1960